

LW5S 产品说明

版本1.0

一、产品概述

- 内置高性能，低功耗微处理器
- 实用的报警功能
 - 断相
 - 过热
 - 过流
 - 负载断线
- 一路继电器输出
 - 3A AC250V
 - 3A DC30V
 - 最大电流150A
- 外设特点
 - 支持4-20mA和0-5V（电位器）两路给定
 - 两路开关量输入
 - 主回路宽范围输入电压(AC260-440V)
- 高效散热方案使得体积小、重量轻
- 便于集中控制的RS485通讯

二、安装尺寸

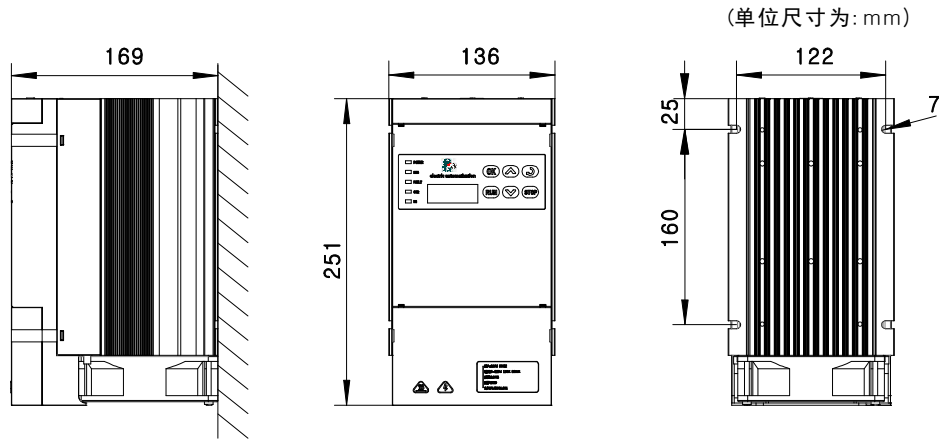

三、按键操作

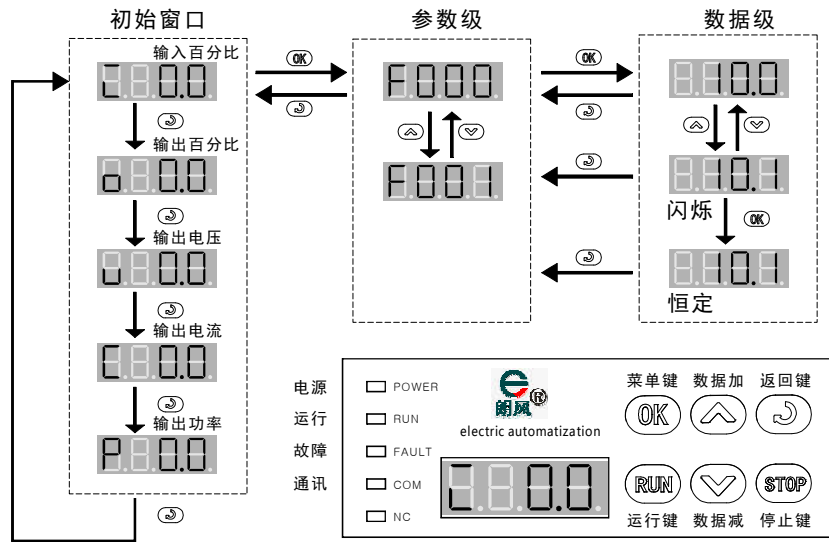

四、端子说明

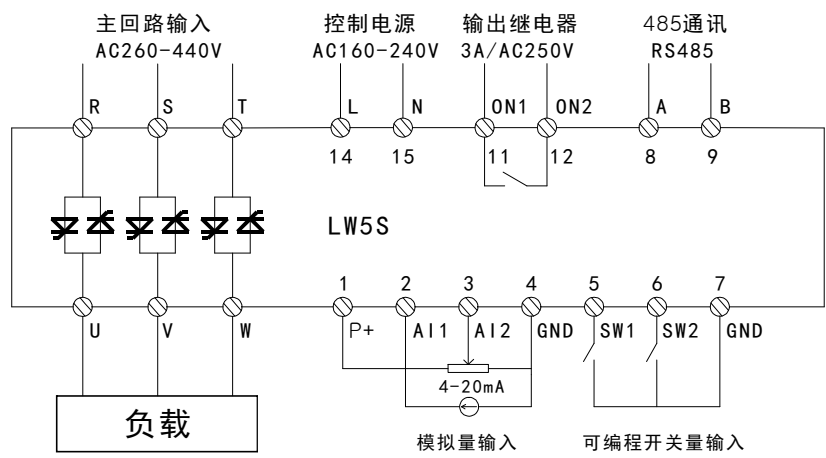

SW1默认为起停信号，SW2默认A11与A12之间切换，闭合A12给定信号有效，断开A11给定信号有效。

五、通讯

LW5S系列功率调节器支持MODBUS通讯协议。MODBUS支持3、4、6、16共4种功能，F-35从站地址：1-247，F-36波特率：2400 4800 9600 19200 38400，F-37数据格式：8n2 8e1 8o1三种数据格式。参数值是16位无符号寄存器，不支持小数点，如要写56.7需先调整为整数567后再写。

注意：每帧数不能超过20个字节，所以每帧数最多读取10个参数。

▶ 读保持寄存器帧格式

0	1	2	3	4	5	6	7
设备地址	03H	参数地址	参数地址	寄存器数	寄存器数	CRC H	CRC L

▶ 预置单个寄存器帧格式

0	1	2	3	4	5	6	7
设备地址	06H	参数地址	参数地址	数据	数据	CRC H	CRC L

六、故障与维护

1、故障表

故障代码	说明
E002	主电源故障，可能故障原因： 1、主回路进线无电压或与铭牌不相符。 2、参照接线图。
E003	过电流，检测电流大于额定电流1.25倍报警被激活。可能故障原因： 1、负载突然变小或短路 2、晶闸管损坏。
E004	负载断线，断线电流=给定百分比*额定电流*负载门限，电流给定值与实际检测值之差大于断线电流，报警被激活。可能故障原因： 1、负载断开 2、负载电流过小 3、负载断线门限（F-45）设置过小。
E005	调节器过热，检测到散热器温度大于85℃，报警被激活。可能故障原因： 1、环境温度高于45℃ 2、风机损坏 3、风道积灰

七、基本参数说明

以下参数为简明操作参数。参数属性R为只读参数，RW为可读写参数。请在停机状态下修改参数。

参数号	说明	范围值	出厂值	可见更改和属性
F-000	有效输出	0-100.0 [%] 0.1%	-	R
F-001	有效输入	0-100.0 [%] 0.1%	-	R
F-002	输出电压	0-100.0 [V] 0.1V	-	R
F-004	A相输出电流	0-100.0 [%] 0.1A	-	R
F-005	B相输出电流	0-3000.0 [V] 0.1A	-	R
F-006	C相输出电流	0-3000.0 [A] 0.1A	-	R
F-007	输出功率	0-3000.0 [KW] 0.1KW	-	RW
F-008	起停状态 0:停止 1:运行	0-1 1	0	RW
F-009	数字给定信号输入	0-100.0 [%] 0.1%	0	RW
F-010	起停控制方式选择 0:外部开关量 1:面板 2:通讯	0-2 1	0	RW
F-011	给定信号类型选择 0:模拟量 1:数字量	0-1 1	0	RW
F-012	电流模拟量类型 0: 0-20mA 1: 4-20mA 2:综合斜率控制	0-2 1	1	RW
F-013	斜坡上升时间 斜坡处理前的信号从0.0%上升到100%所需时间	0-120 1	2	RW
F-014	斜坡下降时间 斜坡处理前的信号从100%下降到0.0%所需时	0-120 1	2	RW
F-015	输出上限 输出最大值限制	0-100% [%] 0.1%	100	RW
F-016	输出下限 输出最小值设定	0-100% [%] 0.1%	0	RW
F-017	比例 PID控制比例系数	0-200 1	80	RW
F-018	积分 PID控制积分时间	0-200 1	5	RW
F-019	微分 PID控制微分时间	0-200 1	0	RW
F-020	反馈信号来源 0: 电压 1: 电流 2: 功率	0-100.0 [%] 0.1%	0	RW
F-021	限制器信号来源 0: 电流 1: 电压	0-1 1	0	RW
F-022	限制百分比 对限制信号百分比设置	0-100% 0.1%	100	RW
F-023	控制模式 0: 移相闭环 1: 移相开环 2: 过零触发	0-2 1	0	RW
F-027	A11高端校正 设置此参数使得20mA对应给定输入100%	0-100% 1%	100	RW
F-029	A12高端校正 设置此参数使得5V对应给定输入100%	0-100% 1%	100	RW
F-035	设备地址 此参数设置Modbus地址	0-247 1	123	RW
F-036	波特率 0: 2400 1: 4800 2: 9600 3: 19200 4: 38400	0-4 1	2	RW
F-037	数据格式 0: 8n2 数据位8位，无校验，2个停止位 1: 8e1 数据位8位，偶校验，1个停止位 2: 8o1 数据位8位，奇校验，1个停止位	0-2 1	1	RW
F-040	可编程继电器 0: 故障 1: 启动状态输出	0-1 1	0	RW
F-041	前一次故障	0-1 1	-	RW
F-042	过流保护允许 0: 禁止 1: 允许	0-1 1	1	RW
F-043	断相保护允许 0: 禁止 1: 允许	0-1 1	1	RW
F-044	负载保护允许 0: 禁止 1: 允许	0-1 1	1	RW
F-045	负载不平衡门限	10-70 [%] 1%	70	RW
F-046	晶闸管过热保护允许 0: 禁止 1: 允许	0-1 1	1	RW
F-048	额定电压 与铭牌上相同，可根据实际负载修改此参数，达到保护设备的目的。 注意：不能大于铭牌标定值	0-3000 [V] 0.1V	380	RW
F-049	额定电流 与铭牌上相同，可根据实际负载修改此参数，达到保护设备的目的。 注意：不能大于铭牌标定值	0-3000 [A] 0.1A	与铭牌一致	RW
F-050	额定频率 0: 50HZ 1: 60HZ 2: 自动跟踪	0-1 1	0	RW

LW5S Operation Manual

Version 1.0

1. Product Description

- Built-in High-performance, Low-power Microcontroller
- Efficient cooling solution such small size, light weight
- One relay output
 - 3A AC250V
 - 3A DC30V
- Practical alarm function
 - Phase failure
 - Overheat
 - Overcurrent
 - Load break
- To facilitate centralized control RS485 communication
- Max Current 150A

2. Size

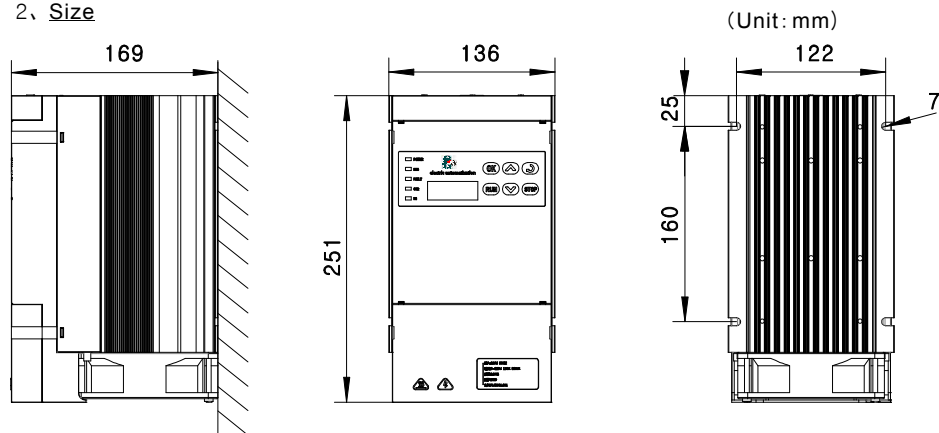

3. Keyboard operation

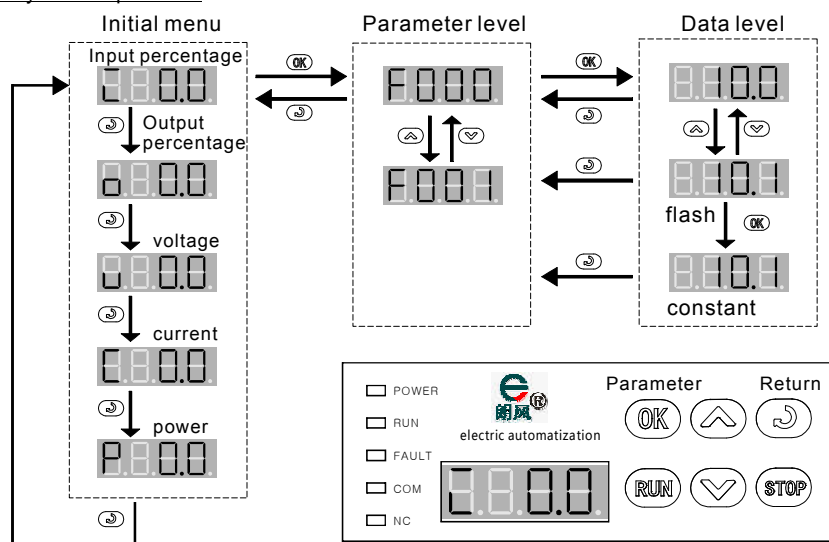

4. Terminal description

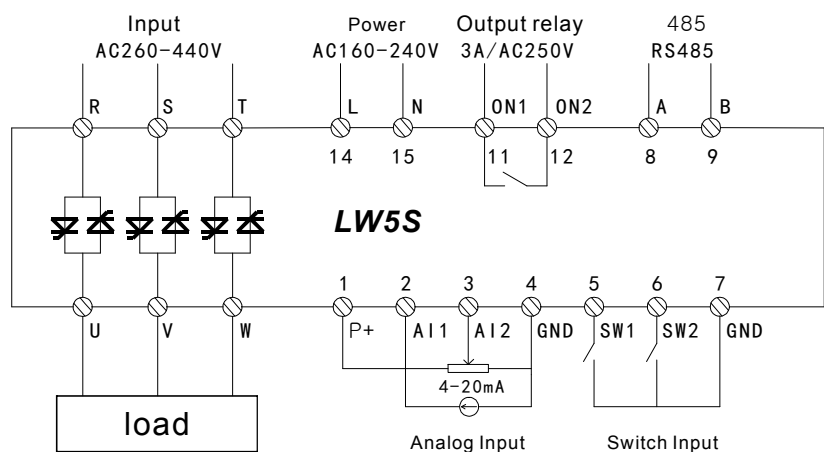

The default is stop start signal SW1, SW2 default switch between A11 and A12, closed A12 given signal is valid, disconnect A11 given signal is valid.

5. Communication

LW5S Series power regulator supports Modbus protocols. Modbus supports 3, 4, 6, 16, totally 4 functions, F-35: slave station address: 1-247, F-36 baud rate: 2400 4800 9600 19200 38400. F-37: data format: 8n2 8e1 8o1, 3 types. Parameter value is 16bits no signal register, decimal point is not supported. For example, before writing 56.7, it should be adjusted as 567 and then re-write.

Notice: every frame cannot exceed 20 bytes, so every frame can maximum read 10 parameters

▶ Read Holding Registers frame format

0	1	2	3	4	5	6	7
Addr	Function 03H	Starting Address Hi	Starting Address Lo	No. of Points Hi	No. of Points Lo	CRC H	CRC L

▶ Preset Single Register frame format

0	1	2	3	4	5	6	7
Addr	Function 06H	Starting Address Hi	Starting Address Lo	Preset Data Hi	Preset Data Lo	CRC H	CRC L

6. Fault and maintenance

1. Fault list

fault code	description
E002	Main power fault, possible fault reason: 1. No voltage of mail loop or not the same of nameplate. 2. Synchronous cable of terminal 12 is not connected, please refer to the wiring drawing.
E003	Overcurrent, measured current exceeds 1.25 time of rated current, possible reason: 1. Load changes rapidly or short-circuit. 2. Thyristor breaks.
E004	Load-off, load off current = set-point percentage * rated current * load threshold, alarms when difference between set-pint and measured current is bigger than load off current. Possible reason: 1. Load off 2. Load current is small 3. Setting of(F-45)is small
E005	Overheat of regulator, heat-sink temperature is bigger than 85, possible reason: 1. Ambient temperature is higher than 45. 2. Fan breaks. 3. Dust on the ventilation path.

7. basic parameter

Above chapter is the brief operation parameter, R: readable parameter, RW: readable and writeable parameter. Please change parameter when regulator stops.

parameter no.	description	range	default	Attributes
F-000	Valid output	0-100.0 [%] 0.1%	-	R
F-001	Valid input	0-100.0 [%] 0.1%	-	R
F-002	Output voltage	0-100.0 [%] 0.1V	-	R
F-004	A phase Output current	0-100.0 [%] 0.1A	-	R
F-005	B phase Output current	0-3000.0 [V] 0.1A	-	R
F-006	C phase Output current	0-3000.0 [A] 0.1A	-	R
F-007	Output power	0-3000.0 [KW] 0.1KW	-	RW
F-008	Start/stop signal Signal source of start/stop 0: switch off 1: switch on	0-1 1	0	RW
F-009	Digital setting signal input	0-100.0 [%] 0.1%	0	RW
F-010	Start-stop control mode selection 0: External switch 1: panel 2: communication	0-2 1	0	RW
F-011	Given signal type selection 0: Analog 1: Digital	0-1 1	0	RW
F-012	Current analog type 0: 0-20mA1: 4-20mA 2: Integrated slope control	0-2 1	1	RW
F-013	Ramp-up time Signal processing before the ramp from 0.0% to 100% of the time required	0-120 1	2	RW
F-014	Ramp-down time Before the ramp signal processing dropped from 0.0% to 100% of the time required	0-120 1	2	RW
F-015	Output ceiling Maximum output limit	0-100% [%] 0.1%	100	RW
F-016	Output limit Output minimum value	0-100% [%] 0.1%	0	RW
F-017	Proportion PID control proportional factor	0-200 1	80	RW
F-018	Integral PID control integral time	0-200 1	5	RW
F-019	Differential PID control differential time	0-200 1	0	RW
F-020	Feedback signal source 0: Voltage 1: current 2: power	0-100.0 [%] 0.1%	0	RW
F-021	Limiter signal source 0: Current 1: Voltage	0-1 1	0	RW
F-022	Limit percent Set as a percentage of the limit signal	0-100% 0.1%	100	RW
F-023	Control mode 0: Closed-loop phase shift 1: Open loop phase shift 2: Zero trigger	0-2 1	0	RW
F-027	A11 end correction This parameter is set so that 20mA corresponds to a given input 100%	0-100% 1%	100	RW
F-029	A12 end correction This parameter is set so that 5V corresponds to a given input 100%	0-100% 1%	100	RW
F-035	Device Address This parameter sets the Modbus address	0-247 1	123	RW
F-036	Baud Rate 0: 2400 1: 4800 2: 9600 3: 19200 4: 38400	0-4 1	2	RW
F-037	Data format 0: 8n2 Date bit 8 bits, no calibration, 2 stop bits 1: 8e1 Date bit 8 bits, parity - checking, 1 stop bits 2: 8o1 Date bit 8 bits, odd parity -checking, 1stop bits	0-2 1	1	RW
F-040	Output relay 0: Fault 1: Start status	0-1 1	0	RW
F-041	Previous fault	0-1 1	-	RW
F-042	Allow overcurrent protection 0: Disable 1: Enable	0-1 1	1	RW
F-043	Phase protection permit 0: Disable 1: Enable	0-1 1	1	RW
F-044	Load fault protection enables 0: Disable 1: Enable	0-1 1	1	RW
F-045	Load-off threshold	10-70 [%] 1%	70	RW
F-046	Thyristor thermal protection allows 0: Disable 1: Enable	0-1 1	1	RW
F-048	Rated voltage :The same as nameplate. Data can be changed according to actual load, for the purpose of protecting device Notice: cannot exceed nominated value on the nameplate	0-3000 [V] 0.1V	380	RW
F-049	Rated current: The same as nameplate. Data can be changed according to actual load, for the purpose of protecting device Notice: cannot exceed nominated value on the nameplate	0-3000 [A] 0.1A	-	RW
F-050	Frequency 0: 50HZ 1: 60HZ 2: Automatic tracking	0-1 1	0	RW